

## SECTION G

### THE PROPELLER SHAFT

	<i>Section</i>
<b>General description</b>	
<b>Propeller shaft</b>	
Dismantling .. .. .	G.4
Lubrication .. .. .	G.1
Reassembling .. .. .	G.6
Removing .. .. .	G.3
Replacing .. .. .	G.7
<b>Wear</b>	
Examination and check .. .. .	G.5
Testing .. .. .	G.2

### GENERAL DESCRIPTION

The propeller shaft and universal joints are of the Hardy Spicer type with needle-roller bearings.

A single shaft connects the rear axle and the gearbox. To accommodate fore and aft movement of the axle a sliding joint of the reverse spline type is fitted between the gearbox and the front universal joint flange. Each joint consists of a centre spider, four needle-roller bearing assemblies, and two yokes.

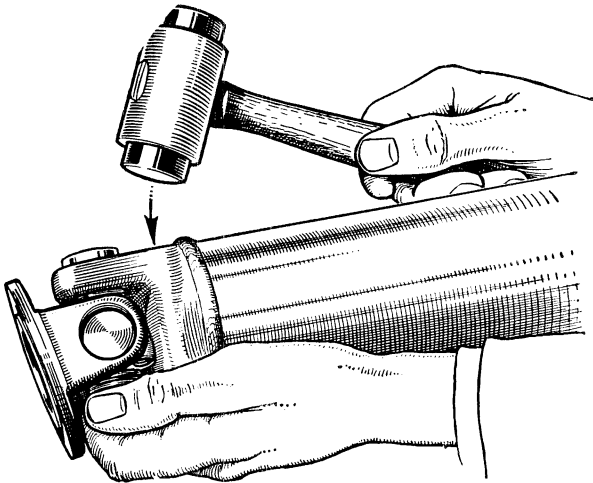

Fig. G.1

*Where to apply light blows to the yoke after removing the retaining circlip*

### Section G.1

#### LUBRICATING THE UNIVERSAL JOINTS

A lubricator is fitted to each front and rear spider, and should be charged fully after overhauling and subsequently given three or four strokes with the grease gun every 1,000 miles (1600 km.). The correct lubricant is grease to Ref. D (page P.2).

If a large amount of grease exudes from the oil seal the joint should be dismantled and new oil seals fitted.

The sliding joint is automatically lubricated from the gearbox.

### Section G.2

#### TESTING FOR WEAR

Wear on the thrust faces is ascertained by testing the lift in the joint either by hand or with the aid of a length of wood suitably pivoted.

Any circumferential movement of the shaft relative to the flange yokes indicates wear in the needle-roller bearings, or in the splined shaft in the case of the forward joint.

G.2

### Section G.3

#### REMOVING THE PROPELLER SHAFT

Before removing the bolts and nuts securing the propeller shaft universal joint flange to the rear axle flange carefully mark the flanges to assist in refitting them in their original positions. **This is important.**

Remove the bolts securing the propeller shaft to the rear axle flange. The shaft can now be removed from the car downwards and rearwards.

### Section G.4

#### DISMANTLING THE PROPELLER SHAFT

Remove the enamel and dirt from the snap rings and bearing faces. Remove all the snap rings by pinching their ears together with a pair of thin-nosed pliers and prising them out with a screwdriver.

If a ring does not slide out of its groove readily tap the end of the bearing race slightly to relieve the pressure against the ring. Remove the lubricator from the journal and, holding the joint in one hand, tap the radius of the yoke lightly with a copper hammer. The bearing should begin to emerge; turn the joint over and finally remove

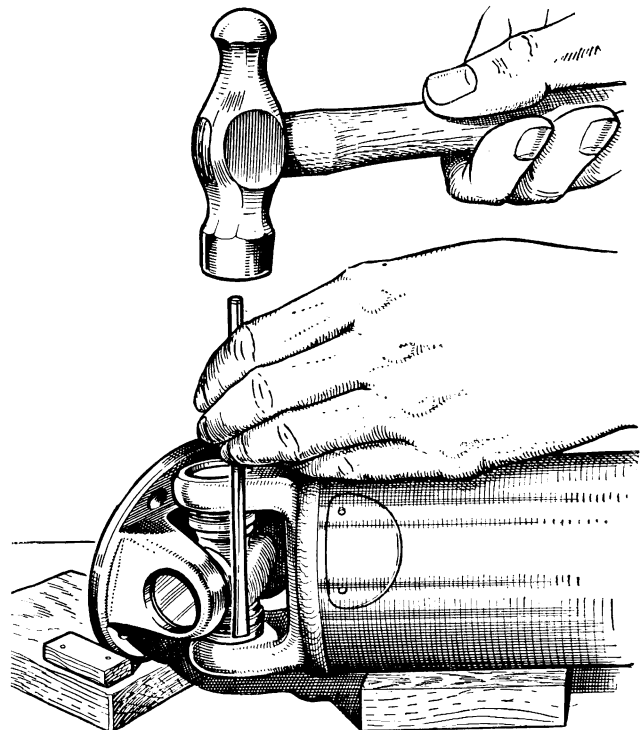

Fig. G.2

*When dismantling a universal joint the bearings may be tapped out with a small-diameter rod from the inside as shown. Take care not to damage the roller races*

with the fingers. If necessary, tap the bearing race from inside with a small-diameter bar, taking care not to damage the bearing face, or grip the needle bearing race in a vice and tap the flange yoke clear.

Be sure to hold the bearing in a vertical position, and when free remove the race from the bottom side to avoid dropping the needle rollers.

Repeat this operation for the opposite bearing.

Rest the two exposed trunnions on wood or lead blocks to protect their ground surfaces, and tap the top lug of the flange yoke to remove the bearing race.

Turn the yoke over and repeat the operation.

### Section G.5

#### TO EXAMINE AND CHECK FOR WEAR

The parts most likely to show signs of wear after long usage are the bearing races and the spider journals. Should looseness, load markings, or distortion be observed, the affected part must be renewed complete; no oversized journals or races are provided.

It is essential that the bearing races are a light drive fit in the yoke trunnions. In the event of wear taking place in the yoke cross-holes, rendering them oval, the

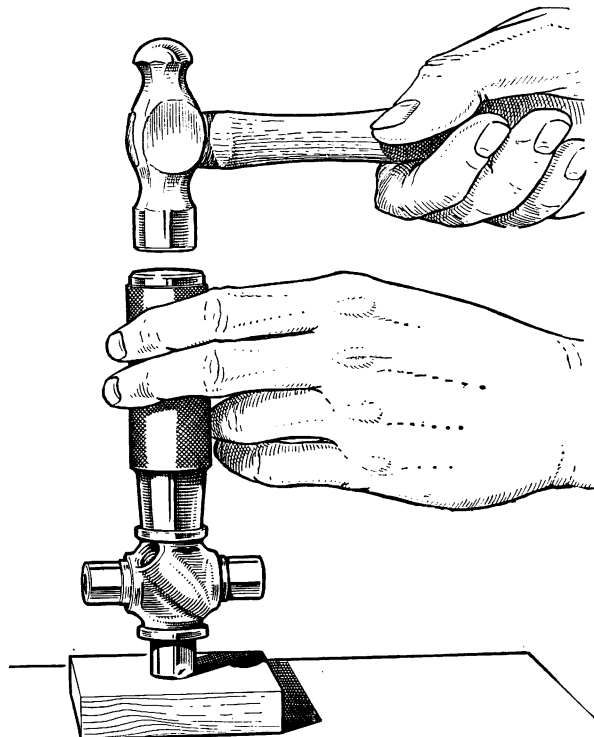

Fig. G.3

*When replacing the gasket retainer use should be made of a hollow drift to tap it into place without damage*

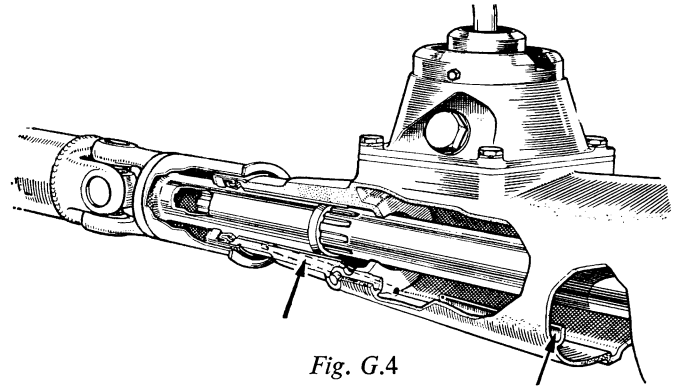

Fig. G.4

*The sliding joint, showing the oilways leading oil from the gearbox*

yokes must be renewed. In case of wear in the cross-holes in the fixed yoke, which is part of the tubular shaft assembly, it should be replaced by a complete tubular shaft assembly.

### Section G.6

#### REASSEMBLING THE SHAFT

See that all the drilled holes in the journals are thoroughly cleaned out and free of grease.

Assemble the needle rollers in the bearing races and fill with grease. Should difficulty be experienced in retaining the rollers under control, smear the walls of the races with grease to Ref. D (page P.2) to retain the needle rollers in position while reassembling.

Insert the spider in the flange yoke, ensuring that **the lubricator boss is fitted away from the yoke**. Using a soft-nosed drift, about  $\frac{1}{32}$  in. (.8 mm.) smaller in diameter than the hole in the yoke, tap the bearing into position. Repeat this operation for the other three bearings. Replace the circlips and be sure that these are firmly located in their grooves. If the joint appears to bind tap lightly with a wooden mallet: this will relieve any pressure of the bearings on the end of the journals.

It is always advisable to replace the cork gasket and the gasket retainers on the spider journals by means of a tubular drift shown in Fig. G.3. The spider journal shoulders should be shellacked prior to fitting the retainers to ensure a good oil seal.

### Section G.7

#### REPLACING THE PROPELLER SHAFT

Wipe the faces of the flanges clean and place the propeller shaft in position on the car. Ensure that the flange registers engage correctly, that the components are replaced in exactly the same relation as before removal, and that the joint faces bed down evenly all round. Insert the bolts and tighten the self-locking nuts.