

SECTION K
THE FRONT SUSPENSION
(TORSION BAR)

	<i>Section</i>
General description	
Maintenance	
Brake-drum and hub—removal and replacement	K.6
Brake-plate—removal and replacement	K.7
Lower arms—removal and replacement	K.5
Swivel pin assembly	
Dismantling and reassembling	K.4
Removal and replacement	K.3
Tools—special	K.8
Torsion bar	
Removing	K.2
Trimming	K.1

For additional information see Section KK

KEY TO THE FRONT SUSPENSION COMPONENTS (Left-hand Side)

No.	Description	No.	Description	No.	Description
1.	Pin—swivel—L/H.	27.	Plain washer for nut.	69.	Plain washer for fork bolt.
2.	Shaft—stub—L/H.	29.	Bolt—brake-plate to swivel pin.	70.	Nut for fork bolt.
3.	Circlip for shaft.	30.	Nut for bolt.	71.	Spring washer for nut.
4.	Link—upper—L/H.	31.	Spring washer for nut.	72.	Screw—front to rear arm.
5.	Lubricator—link.	48.	Brake-drum.	73.	Nut for screw.
6.	Seal—upper link to swivel pin.	49.	Screw—drum to hub.	74.	Spring washer for nut.
7.	Plug and stop plate assembly—upper link.	50.	Pin—upper link (pivot).	75.	Plain washer for eyebolt.
8.	Link—lower—L/H.	51.	Bush—pivot pin (rubber).	76.	Nut for eyebolt.
9.	Plug.	52.	Washer for pivot pin (rear).	77.	Spring washer for nut.
10.	Bush.	53.	Nut—pivot pin to link.	79.	Bolt—tie-bar to fork.
11.	Lubricator—lower link.	54.	Tab washer for nut.	80.	Nut for bolt.
12.	Seal—lower link to swivel pin.	55.	Nut—pivot pin to shock absorber arm.	81.	Spring washer.
13.	Pivot—lower arm—outer.	56.	Arm—lower—front.	82.	Torsion bar.
14.	Hub assembly.	57.	Arm—lower—rear.	83.	Vernier bracket.
15.	Stud—wheel.	58.	Thrust washer for pivot.	84.	Bolt—vernier bracket.
16.	Nut for wheel stud.	59.	Ring—sealing.	85.	Locknut for bolt.
17.	Seal—hub oil.	60.	Nut for pivot.	86.	Bolt—vernier bracket to frame.
18.	Bearing—hub inner.	61.	Spring washer for nut.	87.	Nut for bolt.
19.	Spacer—bearing.	62.	Eyebolt—lower arm to body.	88.	Spring washer.
20.	Bearing—hub outer.	63.	Spigot—pivot—rear.	89.	Plain washer.
21.	Nut to stub shaft—L.H.T.	64.	Pin—fulcrum—eyebolt to lower arm.	90.	Retainer—plate.
22.	Washer—bearing-retaining.	65.	Bush—fulcrum pin (rubber).	91.	Abutment bracket.
23.	Cap—oil-retaining.	66.	Nut for fulcrum pin.	92.	Bolt.
24.	Lever—steering—L/H.	67.	Spring washer for nut.	93.	Nut.
25.	Key—lever to swivel pin.	68.	Fork bolt—tie-bar to lower arm.	94.	Plain washer.
26.	Nut for lever.				

GENERAL DESCRIPTION

The independent front suspension comprises torsion bars disposed longitudinally and splined into arms attached to the lower ends of each swivel pin. At their upper ends the swivel pins are linked to the hydraulic damper arms.

The grease nipples provided at the swivel pin links are the only points requiring lubrication attention, the inner ends of the lower arms being anchored to the frame members in flexible rubber bushes.

Tie-rods between the forward side of the lower suspension arms and the frame members maintain rigidity of the assembly during acceleration and braking and abnormally rough road conditions.

The trim of the suspension is adjusted at the rear end of each torsion bar.

MAINTENANCE

NOTE.—Rubber bushes are used in the suspension: it is therefore most important not to lubricate these components with oil.

Normal maintenance is confined to lubrication of the linkage.

The grease gun should be applied to the nipples at the top and bottom of the steering swivel pins every 1,000 miles (1600 km.). The recommended lubricant is grease to Ref. C (page P.2).

Section K.1

TRIMMING THE TORSION BARS

The adjuster provided at the rear end of each torsion bar should be used to correct any list on the car which develops if the torsion bars do not settle evenly.

To carry out this adjustment raise the front of the car until the road wheels are clear of the ground and remove the hub and disc wheel.

Suitable supports must be placed beneath the chassis and the car weight rested upon them. Place the supports beneath the forward end of the front door sills.

Place a jack beneath the outer end of the lower suspension arm and raise it until the hydraulic damper arm at the top of the swivel pin is just clear of the rubber rebound pad. Care must be taken to see that the jack is not liable to slip while it is taking the torsion bar load.

Remove the nut and bolt securing the tie-rod to the fork on the suspension arm and remove the nuts and bolts retaining the forward half of the arm.

Disengage the lower swivel pin link from the suspension arm and lower the jack until the load is taken off the torsion bar.

Slacken the locknut on the adjusting bracket screw and rotate the screw in the required direction. Turning

the adjusting screw in an anti-clockwise direction will set the car up and turning it in a clockwise direction will lower it.

Tighten the adjusting screw locknut after the adjustment is completed.

If the adjusting lever is rotated one spline on the torsion bar the car will be raised approximately 1½ in. (3.8 cm.).

NOTE.—Adjustment must not be undertaken unless the load has been taken off the torsion bar.

Assembly is a reversal of the dismantling procedure.

Section K.2

REMOVING THE TORSION BAR

Raise the front of the car until the road wheels are clear of the ground.

Remove the hub disc and wheel.

Place suitable supports beneath the forward end of the front door sills and allow the weight of the car to rest upon them.

Place a jack beneath the outer end of the rear portion of the lower suspension arm and raise it until the hydraulic damper arm at the top of the swivel pin is just clear of the rubber rebound pad.

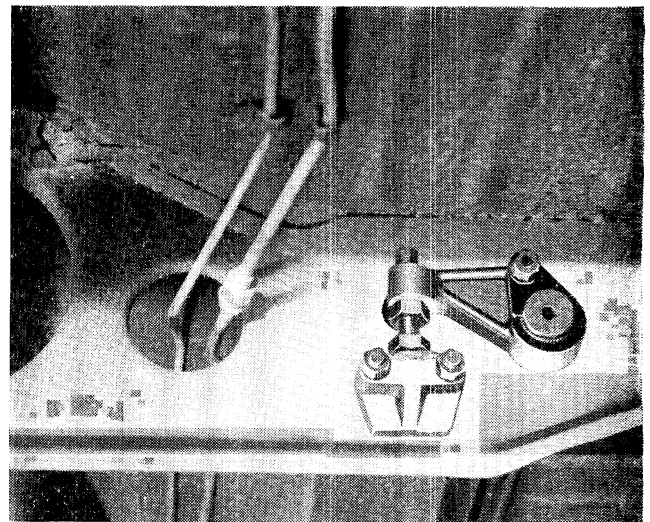

Fig. K.1

The locknut for the torsion bar rear hub adjusting screw

Withdraw the securing bolt and disengage the tie-rod end from the fork on the suspension arm. Remove the nuts and bolts securing the halves of the lower suspension arm and remove the front half of the arm. Disengage the swivel pin link from the suspension arm and lower the jack until the load is off the torsion bar.

Mark the position of the torsion bar relative to the lower arm and rear bracket; use a pencil and chalk—do not scratch or centre-punch the torsion bar.

Take out the nut and bolt securing the torsion bar rear end adjusting arm to the cross-member; remove the retaining plate and withdraw the adjusting arm.

Withdraw the torsion bar from the front suspension arm splines by pulling rearwards on the bar whilst a second operator taps the rear face of the lower suspension arm with a **copper** or **hide** mallet. Pull gently during the latter stages of this operation as the bar may be released with a rush. Mark the bar with chalk to indicate the side from which it was taken.

See Section KK for details on replacing and resetting the torsion bars.

Section K.3

REMOVAL AND REPLACEMENT OF THE SWIVEL PIN ASSEMBLY

The following instructions are for removing the swivel pin assembly with the brake-drum, hub, and brake-plate attached. These parts may, however, be removed first, in accordance with the instructions given in Sections K.6 and K.7, and the brake-plate tied up out of the way with the flexible hydraulic pipe still attached to its connection on the valance, thus obviating the need to bleed the brakes after assembly.



Fig. K.2

When disconnecting a flexible brake hose prevent the hose from turning by holding a spanner on the hexagon nut provided

Removal

Raise the front of the car and remove the wheel. Place a suitable jack beneath the suspension arm and lower the car until it is just taking the torsion bar load and the hydraulic damper arm clears the rubber rebound pad beneath it.

Unscrew the small union nut securing the hydraulic brake feed pipe to the flexible pipe on the wing valance. Detach the flexible pipe by unscrewing the large hexagon nut, using a $\frac{3}{8}$ -in. spanner on the hexagon provided to prevent the hose from turning (see Fig. K.2).

Remove the split pin and slacken off the slotted nut securing the steering tie-rod ball joint to the steering arm. Tap the circumference of the steering arm eye and, placing a support above the steering arm, use a suitable brass drift applied to the ball joint nut to drive the ball pin from its tapered seating.

Tap back the lock washer and slacken the nut on the rear end of the bolt securing the swivel pin to the hydraulic damper arm. Remove the split pin and slacken the nut at the opposite end of the bolt. Tap the damper arm eye, place a support behind it, and drive the bolt from its tapered seating with a brass drift.

Support the swivel pin assembly and withdraw the pin from the damper arm, leaving the assembly free to be removed for further dismantling.

Remove the nut and bolt securing the tie-rod to the fork on the suspension arm and remove the nuts and bolts retaining the forward half of the arm.

Disengage the lower swivel pin link from the suspension arm and lower the jack until the load is taken off the torsion bar.

Replacement

The swivel pin assembly may be replaced without difficulty by carrying out the removal instructions in the reverse order except that the nut retaining the top swivel pin rubbers should be left slack until the car is standing once more upon its wheels. Tighten the nut until the large washer is pulled up tight against the shoulder on the bolt and then lock in position by tapping over the lock washer.

See Section MM.7 for details on bleeding the hydraulic brake system.

Section K.4

DISMANTLING AND REASSEMBLING THE SWIVEL PIN ASSEMBLY

Remove the swivel pin assembly as detailed in Section K.3 and remove the rubber bushes from the upper swivel pin link; remove the thrust washers and rubber sealing rings from the lower link. Unscrew the upper and lower

links from the swivel pin ends. **The left-hand pin has a left-hand thread at each end.**

Thoroughly clean off and dry all the parts and examine them for wear.

Check the swivel pin links for wear in the threaded bores. When new the links should be a free turning fit on the swivel pin, but without slackness. In service a certain amount of slackness is permissible, but when any doubt arises a new swivel link assembly should be fitted. Lubrication of the swivel link assemblies at the intervals recommended will considerably reduce wear on the threads and should be carried out regularly.

Check the condition of the upper rubber bushes and the lower thrust washers and rubber seals and renew as required. The lower thrust washers should have flat and parallel faces.

Check that the grease nipples are clear.

When reassembling note the following important points:

- (1) The swivel pin and links fitted to the left-hand side of the car have left-hand threads.
- (2) The swivel pin links screw onto the threads on each end of the swivel pin and the threads are waisted at their centre to avoid fouling the pivot bolts passing through the links. Before the pivot bolt is replaced the link must be correctly positioned on the thread.

First screw the link onto the swivel pin until the waisted portion of the swivel pin lines up with the pivot bolt hole. Place the pivot bolt in position in the link and screw the link to the extent of its maximum travel on the swivel pin thread (the total travel is about three complete revolutions). Screw the link back approximately one and a half turns to obtain the maximum clearance for the pivot pin in each direction.

Before the suspension arm is replaced ensure that the rubber seals are fitted correctly.

Section K.5

REMOVING AND REPLACING THE LOWER SUSPENSION ARM

Remove the front half of the lower suspension arm as detailed in Section K.2.

Remove the torsion bar as detailed in Section K.2 and remove the nut and washer securing the arm and fulcrum pin to the eyebolt. Remove the suspension arm.

Before the arm is replaced inspect the fulcrum pin and eyebolt rubber bushes. Renew any defective parts.

The eyebolt is a push fit in the suspension arm and should not be removed unless absolutely necessary.

Section K.6

REMOVING AND REPLACING THE BRAKE-DRUM AND HUB

Prise off the hub cover. Slacken the wheel nuts.

Raise the car until the wheel is clear of the ground.

Unscrew the wheel nuts and remove the wheel.

Prise the grease cap from the hub.

Remove the split pin from the stub axle nut and unscrew the nut, remembering that the axle on the left-hand side of the car has a left-hand thread. Remove the flat washer.

The brake-drum can be removed independently of the hub by the removal of the two countersunk screws.

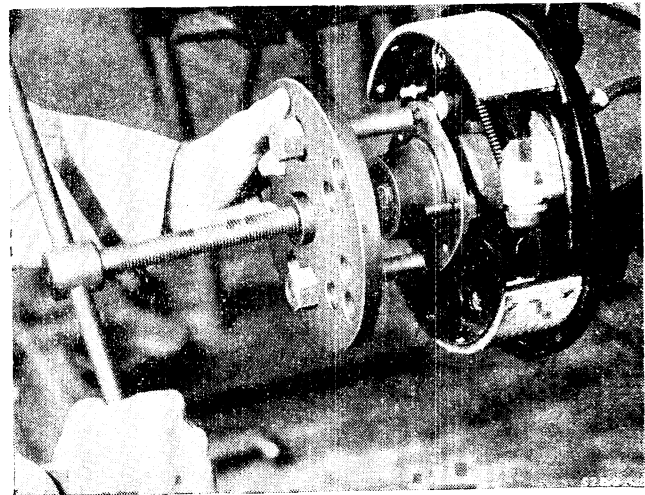

Fig. K.3

Using special tool 18G304 to remove a front hub assembly

Withdraw the hub, using the special hub removing tool 18G304 and adaptor bolts 18G304F (Fig. K.3).

Care must be taken not to damage the oil seals at the rear of the bearing.

Reassembly

Insert the inner ball race into the hub with the thrust side of the race facing inwards towards the pressed-steel spacer. The thrust side may be identified by the fact that it has the part number stamped on it.

Pack the hub with grease to Ref. C, page P.2, and insert the spacer so that the domed end faces the outer bearing.

Replace the outer bearing with the thrust side facing the spacer. Use a soft-metal drift to replace both bearings, tapping them on diametrically opposite sides in order to move them evenly into their housings. Replace the oil seal over the inner bearing with its hollow side facing the bearing. Renew the seal if it is at all damaged.

Replace the hub on the stub axle, using a hollow drift bearing evenly on both inner and outer races of the outer bearing. Tap the hub into position until the stub axle nut can be screwed onto the thread. Continue to tighten the nut until the inner race bears against the stub axle shoulder.

Tighten the nut and align the slots with the split pin hole in the stub axle. **Never slacken back the nut to achieve alignment.**

Finally lock the nut with a split pin.

Section K.7

REMOVING AND REPLACING THE BRAKE-PLATE ASSEMBLY

Remove the brake-drum and hub as detailed in Section K.6.

To remove the brake-plate disconnect the flexible hydraulic brake hose from its union at the wing valance.

If the desired attention can be given without disconnecting the flexible brake pipe the brake-plate assembly can be hung on a suitable portion of the frame to take the load off the flexible pipe.

Unscrew the small union nut securing the metal feed pipe to the flexible pipe. Use a $\frac{3}{8}$ -in. spanner on the hexagon provided above the bracket to prevent the hose from turning while unscrewing the large hexagon nut to detach the flexible pipe (see Fig. K.2).

Unscrew the four bolts and nuts securing the brake-plate to the stub axle flange and remove the brake-plate complete with brake-shoes and wheel cylinders.

Reverse the dismantling sequence to reassemble.

Section K.8

SPECIAL TOOLS

18G304. Hub Remover (basic tool)

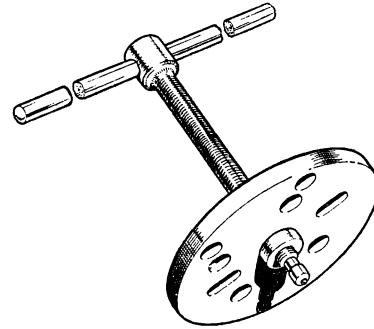

18G304

18G304F. Adaptor Bolts— $\frac{3}{8}$ in. UNF (2)

The remover 18G304 is a basic tool used for numerous applications. When used with the adaptor bolts 18G304F screwed onto the wheel studs the most difficult hub can be withdrawn with ease and without damage.



18G304F

SECTION KK
THE FRONT SUSPENSION
(TORSION BAR)

This Section is a Supplement to Section K

	<i>Section</i>
Replacing and resetting torsion bars	KK.1
Modified torsion bar settings	KK.2

Section KK.1

REPLACING AND RESETTING THE TORSION BARS

A torsion bar which has been fitted and used on one side of the car must on no account be transferred for use on the other side. The torsion bars are only interchangeable when new. They become 'handed' once they have been in service and must from then on always be used on the same side of the car.

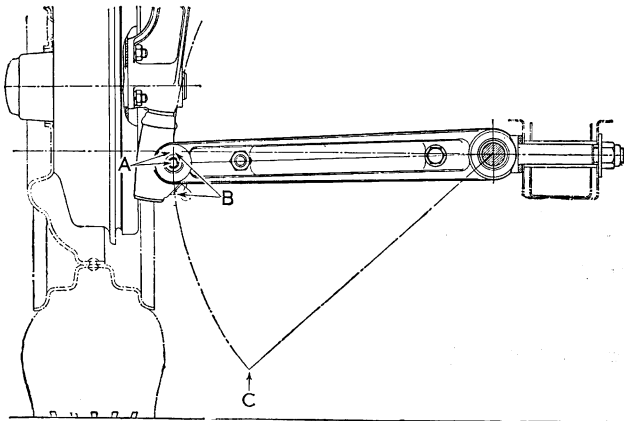

Fig. KK.1

The difference in height between the centres of the lower arm inner and outer pivots under various conditions of loading is indicated in this illustration

- A. Full load of three passengers, driver and full equipment— $\frac{3}{8}$ in. (9.52 mm.).
- B. Unladen— $1\frac{3}{8}$ in. (4.44 cm.).
- C. Assembly position (no load on bar)— $7\frac{9}{16}$ in. (19.2 cm.).

There are 48 splines on each end of the torsion bars, and for each consecutive spline position of the rear end a radial movement of the swivel pin of approximately $1\frac{1}{2}$ in. (3.8 cm.) is provided.

To replace the torsion bar support the front end of the car and adjust the jack beneath the lower suspension arm until there is a difference in height of $7\frac{9}{16}$ in. (19.2 cm.) between the centres of the inner and outer suspension arm swivel bolts.

NOTE.—The car must be standing on a level floor and measurements taken from a horizontal flat plate.

When a new torsion bar is to be fitted this difference in height must be increased to $7\frac{15}{16}$ in. (20.16 cm.) to allow

for the small permanent set which takes place when the bar is loaded for the first time.

Thread the rear end of the torsion bar through the cross-member and engage the front end in the suspension arm.

Position the adjusting bracket on the rear end splines, lining up the bolt hole in the bracket with the slot in the cross-member.

Refit the locating plate and the torsion bar retaining bolt with the bolt head and plain washer positioned against the cross-member. Replace and tighten the nut and spring washer.

Raise the jack until the lower swivel pin link engages the suspension arm. Ensure that the rubber seals and thrust washers are in position and replace the forward half of the suspension arm.

Replace and tighten the suspension arm, swivel link, and tie-rod nuts and bolts.

Lower the car onto level ground and check the difference in vertical height of the inner and outer suspension arm pivot bolts. This measurement should be $1\frac{3}{4}$ in. (4.44 cm.) and be the same on both right-hand and left-hand suspension assemblies.

Section KK.2

MODIFIED TORSION BAR SETTINGS

To improve appearance and road-holding capabilities the torsion bar settings of later cars (from Car Nos. 6786 [R.H.D.] and 6498 [L.H.D.] onwards) have been revised. The effect of these changes is to lower the front of the car slightly. The new settings can be used with advantage for earlier cars.

The revised trim figures are given below. Refer to Fig. KK.1, but note that in condition (A) the outer pivot is now $\frac{1}{8}$ in. (3.18 mm.) **higher** than the inner pivot.

- A. Full load of three passengers, driver and full equipment— $\frac{1}{8}$ in. (3.18 mm.).
- B. Unladen— $\frac{11}{16}$ in. (23.81 mm.).
- C. Assembly position (no load on bar)— $7\frac{1}{16}$ in. (17.94 cm.).

When fitting a new torsion bar $\frac{3}{8}$ in. (9.52 mm.) must be added to the figure given in condition (C), making the total difference in vertical height of the suspension arm inner and outer pivot bolts $7\frac{7}{16}$ in. (18.9 cm.). This will allow for the permanent set which takes place when the bar is loaded for the first time.